



E SERIES ANALOG USER GUIDE

For E100, E100LBY, E100TRM, E200, E200TRM,
E103, E103 RediDock, E203, E203 RediDock

Table of Contents

E100 and E100TRM Phone Map	3	E200 and E200TRM Phones	15
E103 and E103 RediDock Phone Map	4	Unpacking Your Telephone	15
E200 and E200TRM Phone Map	5	Installation	15
E203 and E203 RediDock Phone Map	6	Caution Information	15
		Connecting the Handset Cord	15
		Connecting the Line Cord	15
E100 and E100TRM Phones	7	Features	15
Unpacking Your Telephone	7	Operation	16
Installation	7	Volume	16
Caution Information	7	Indicators	16
Connecting the Handset Cord	7	Calling	16
Connecting the Line Cord	7	Programming	17
Features	7	Program Speed Dials Using Submerged [Store]	
Operation	7	and [Flash]	17
Volume	7	Storing a Number into Memory Keys—[Store]	17
Indicators	8	Programming Flash Timing	17
Calling	8	Programming Pause Timing	17
Programming	8	Flash Hook Function—[Flash]	17
Program Speed Dials Using Submerged [Store]		Message	18
and [Flash]	8	Care and Maintenance	18
Storing a Number into Memory Keys—[Store]	8		
Programming Flash Timing	8		
Programming Pause Timing	8		
Flash Hook Function—[Flash]	9		
Message	9		
Care and Maintenance	9		
		E203 and E203 RediDock Phones	19
		Unpacking Your Telephone	19
E103 and E103 RediDock Phones	10	Installation	19
Unpacking Your Telephone	10	Caution Information	19
Installation	10	Connecting the Power Line Cord	19
Caution Information	10	Handset Battery	19
Connecting the Power Line Cord	10	Features	20
Handset Battery	10	Operation	20
Features	11	Volume Control	20
Operation	11	On-Hook and Off-Hook/Pick-up and Hang-Up	20
Volume Control	11	Hold	20
On-Hook and Off-Hook/Pick-up and Hang-Up	11	Mute	20
Hold	11	Redial	20
Mute	11	Message	20
Redial	11	Page	21
Message	11	Conference	21
Page	12	Registering a Handset	21
Programming	12	Switch Between Base and Handset	21
Program Speed-Dials Using Submerged [Store]		Switch Between Handsets	21
and [Flash]	12	Speed Dialing from the Handset	22
Storing a Number into Memory Keys—[Store]	13	Programming	22
Programming Flash Timing	13	Program Speed Dials Using Submerged [Store]	
Programming Pause Timing	13	and [Flash]	22
Flash Hook Function—[Flash]	13	Storing a Number into Memory Keys—[Store]	22
Message Waiting and Retrieval	13	Programming Flash Timing	22
In Case of Power Outage	13	Programming Pause Timing	22
Care and Maintenance	14	Flash Hook Function—[Flash]	22
		Message Waiting and Retrieval	23
		In Case of Power Outage	23
		Care and Maintenance	23
		Important Safety Instructions	24

E100 and E100TRM Phone Map

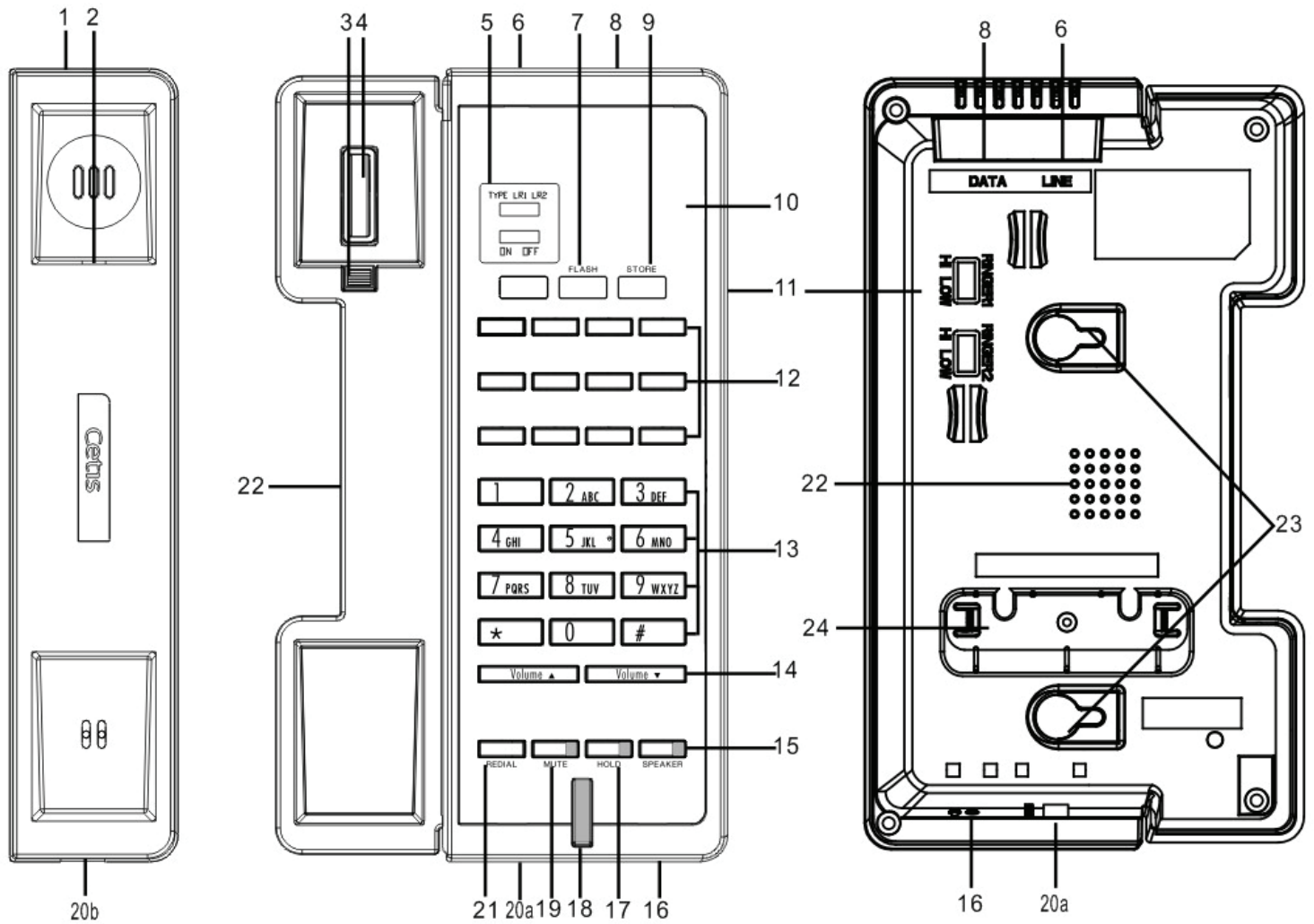

BASE FEATURES AND CONTROLS

- | | |
|---|--|
| 1. Handset | 13. Dialpad |
| 2. Wall mount clip slot | 14. Volume s (increase) and Volume t (decrease) keys |
| 3. Wall mount handset clip | 15. Speaker key |
| 4. Actuator for hookswitch | 16. Microphone |
| 5. Message Waiting Indicator (MWI) switches (submerged) | 17. Hold key |
| 6. RJ-11 line input | 18. Message Waiting Indicator (MWI) light |
| 7. Flash key (submerged) | 19. Mute key |
| 8. RJ-11 data port | 20. a/b. Handset coil cord receptacles |
| 9. Store key (submerged) | 21. Redial key/Pause key |
| 10. Paper faceplate/Plastic overlay | 22. Speaker—half duplex |
| 11. Ringer Volume switch | 23. Wall mount bracket |
| 12. 4, 8, 12, or 0 Memory keys | 24. Desk mount bracket |

E103 and E103 RediDock Phone Map

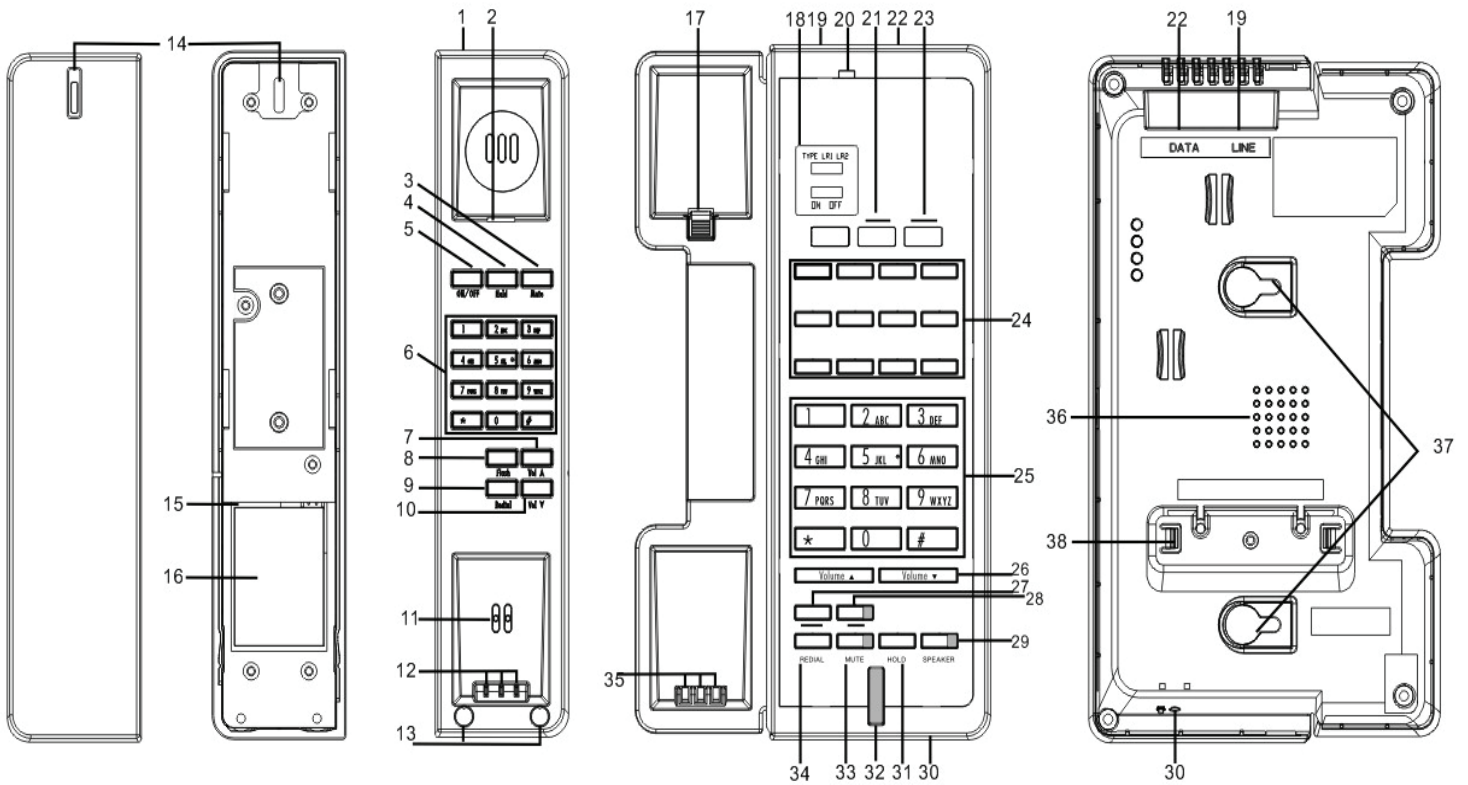

BASE FEATURES AND CONTROLS

- | | |
|--|------------------------------------|
| 1. Handset | 19. RJ-11 line input |
| 2. Wall mount clip slot | 20. LED charging indicator |
| 3. Mute key | 21. Store key (submerged) |
| 4. Hold key | 22. RJ-11 data port |
| 5. On/Off key | 23. Flash key (submerged) |
| 6. Handset dialpad | 24. 4, 8, 12, or 0 Memory keys |
| 7. Handset volume s (increase) | 25. Dial pad |
| 8. Flash key (handset) | 26. Volume s and Volume t keys |
| 9. Redial key (handset) | 27. Page key |
| 10. Handset volume t (decrease) | 28. Line key |
| 11. Microphone (handset) | 29. Speaker key |
| 12. Charging leads (handset) | 30. Microphone (base) |
| 13. Screws and rubber plugs for handset cover and battery access (in separate bag) | 31. Hold key (base) |
| 14. Handset Message Waiting/Ringing Indicator/Speaker key | 32. OneTouch Message Retrieval key |
| 15. Battery tray (handset) | 33. Mute key (base) |
| 16. Battery (handset) | 34. Redial key (base) |
| 17. Wall mount handset clip | 35. Charging leads (base) |
| 18. Message Waiting Indicator switches (submerged) | 36. Speaker—half duplex (base) |
| | 37. Wall mount bracket |
| | 38. Desk mount bracket |

E200 and E200TRM Phone Map

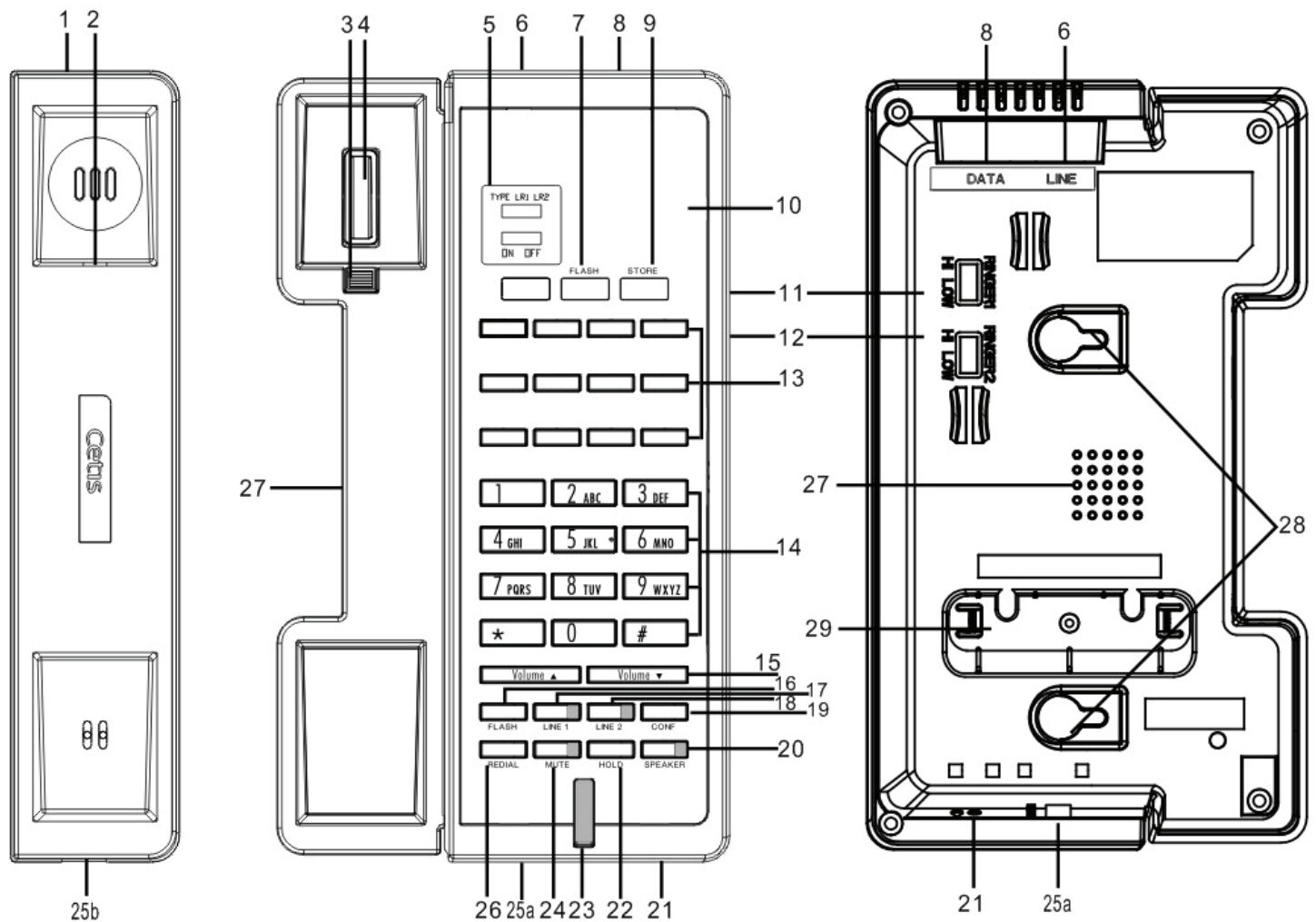

BASE FEATURES AND CONTROLS

- | | |
|--|---|
| 1. Handset | 16. Flash key |
| 2. Wall mount clip slot | 17. Line 1 key |
| 3. Wall mount handset clip | 18. Line 2 key |
| 4. Actuator for hookswitch | 19. Conference key |
| 5. Message Waiting Indicator switches (submerged) | 20. Speaker key |
| 6. RJ-11 line input | 21. Microphone |
| 7. Flash key (submerged) | 22. Hold key |
| 8. RJ-11 data port | 23. Message Waiting Indicator (MWI) light |
| 9. Store key (submerged) | 24. Mute key |
| 10. Paper faceplate/Plastic overlay | 25. a/b. Handset coil cord receptacles |
| 11. Ringer Volume switch | 26. Redial key/Pause key |
| 12. Hi-Lo switch | 27. Speaker—half duplex |
| 13. 4, 8, 12, or 0 Memory keys | 28. Wall mount bracket |
| 14. Dialpad | 29. Desk mount bracket |
| 15. Volume s (increase) and Volume t (decrease) keys | |

E203 and E203 RediDock Phone Map

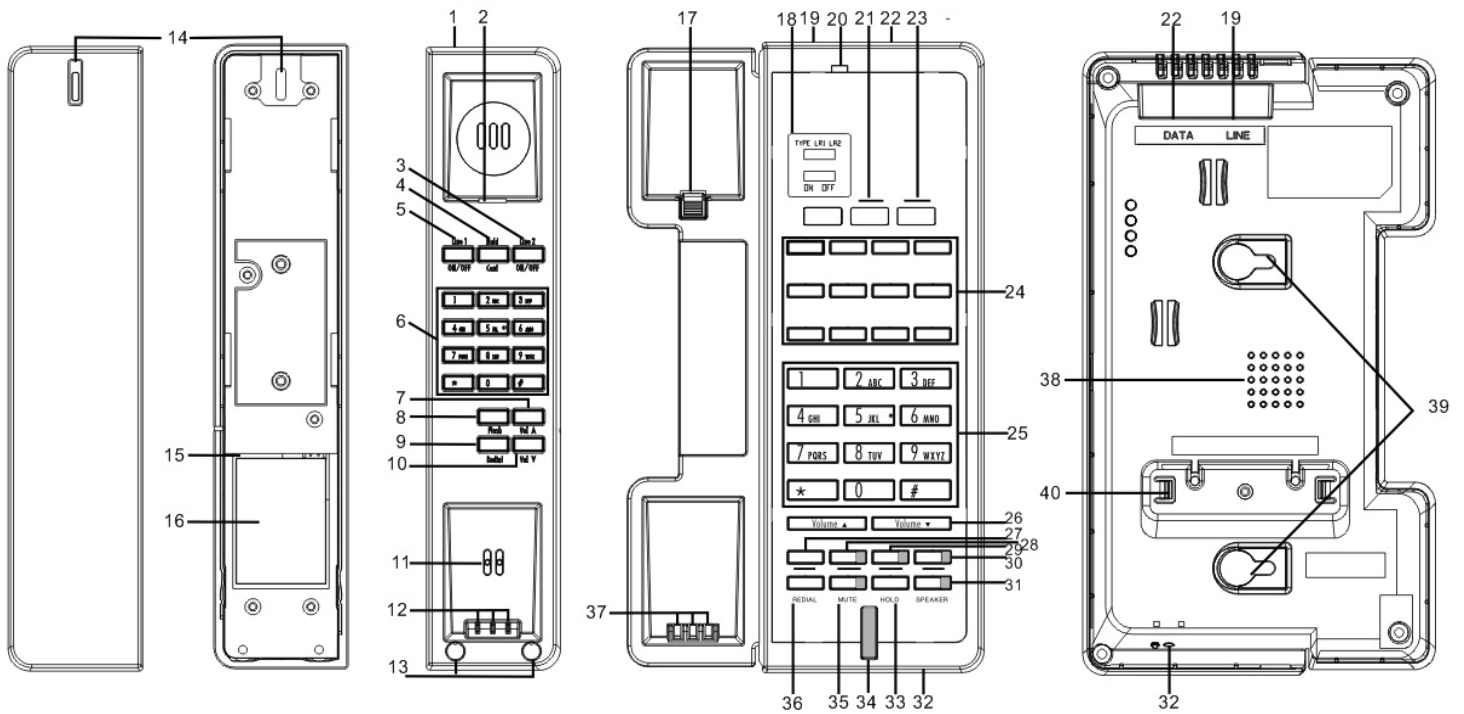

BASE FEATURES AND CONTROLS

- | | |
|---|---|
| <ul style="list-style-type: none"> 1. Cordless handset 2. Wall mount clip slot 3. Line 2 On/Off key 4. Hold/Conf key 5. Line 1 On/Off key 6. Handset dialpad 7. Handset Volume s (increase) 8. Flash key (handset) 9. Redial key (handset) 10. Handset Volume t (decrease) 11. Microphone (handset) 12. Charging leads (handset) 13. Screws for battery access 14. Handset Message Waiting/Ringing indicator/Speaker key 15. Battery tray (handset) 16. Battery (handset) 17. Wall mount handset clip 18. Message Waiting Indicator switches (submerged) 19. RJ-11 line input 20. Paper faceplate/Plastic overlay | <ul style="list-style-type: none"> 21. Store key (submerged) 22. RJ-11 data port 23. Flash key (submerged) 24. 4, 8, 12, or 0 Memory keys 25. Dial pad 26. Volume s (increase) and Volume t (decrease) keys 27. Page key 28. Line 1 key 29. Line 2 key 30. Conf key 31. Speaker key 32. Microphone (base) 33. Hold Key (base) 34. OneTouch message retrieval key 35. Mute key (base) 36. Redial key (base) 37. Charging leads (base) 38. Speaker—half duplex (base) 39. Wall mount bracket 40. Desk mount bracket |
|---|---|

Unpacking Your Telephone

This package should contain the following:

- Telephone base unit
- Handset
- Coiled handset cord
- Straight line cord

Optional items to be ordered separately:

- Wall mount adaptor bracket
- Short line cord for wall mounting

Installation

CAUTION INFORMATION

- Never install telephone or network wiring during a lightning storm.
- Never install telephone or Ethernet jacks in wet locations unless the jack is specifically designed for wet locations.
- Never touch uninstalled telephone wires or terminals unless the telephone line has been disconnected at the network interface.
- Use caution when installing or modifying telephone and network lines.

CONNECTING THE HANDSET CORD

A 10 ft. modular handset coil cord is provided. To install, simply plug one end of the coil cord into the jack at the base of the handset and the other end into the jack located on the end of the telephone base marked Handset.

CONNECTING THE LINE CORD

A 12 ft. modular line cord is provided. To install, simply plug one end of the cord into the modular jack at the top end of the base unit and the other end into the wall jack.

Features

1. **Speed-Dial Memory Keys:** 4, 8, 12, or 0 user programmable speed-dial keys with 32-digit capacity. [Flash] and [Pause] are storable.

Speed-dial memory is non-volatile RAM, so programming is retained without the need for batteries or telephone line power.

2. **FLASH Key:** Generates a 600 ms (0.6 seconds) hook switch “tap” signal. Utilized to access special features on PBX systems. The Flash function is programmable at 100 ms to 1000ms (default is 600 ms). This button is located underneath the faceplate.
3. **HOLD Key:** Controls the “local hold” function. Each time it is pressed, the [Hold] key toggles the local hold mode on or off. An LED indicator located above the [Hold] key displays the on-hold status.
4. **REDIAL Key:** Redials the last-dialed telephone number, up to 32 digits.
5. **STORE Key:** Utilized to program the speed-dial memory keys and the voice mail retrieval touch bar. This button is located underneath the faceplate.
6. **MUTE Key:** Sets the microphone mute function On and Off. The LED indicator above the [Mute] key displays the On/Off status of the mute function. When mute is on, the handset and hands-free microphone audio is turned off. You will be able to hear the party at the other end of your call, but they will not be able to hear you.
7. **SPEAKER Key:** Sets the hands-free speakerphone function On or Off. The LED indicator located above the [Speaker] key displays the status of the speakerphone.
8. **Data Port:** Provides a convenient extension of the telephone line in use for connecting a device such as a modem, fax, or answering machine.

Operation

VOLUME

HANDSET AND SPEAKER VOLUME CONTROL

The handset volume control increases the volume of the handset.

When the handset is off-hook or the Speaker key is engaged on the speakerphone, press the volume control keys to increase or decrease the volume. The handset volume control is an 8-step operation. All models are hearing aid compatible.

RINGER VOLUME CONTROL

The ringer volume control switch is on the bottom side of the phone.

The setting is either Low or HI (High).

INDICATORS

SPEAKER AND MUTE KEYS CONNECTING AND STATUS INDICATORS

Speakerphones are equipped with LED indicators to show the current feature key status.

- Press the Speaker or Mute key to use that service—when in use the red LED lights up.

CALLING

PLACING A CALL USING THE HANDSET

- Lift the handset.
- Dial out by using the numeric dial pad or by pressing a speed dial location.

RECEIVING A CALL USING THE HANDSET OR SPEAKER

On a single-line telephone, when the phone rings, lift the handset (or press the speaker key if you have a speakerphone) to begin the conversation.

PLACING A CALL USING THE SPEAKERPHONE

The E Series speakerphones are equipped with a high quality speakerphone feature to allow hands-free operation. To use, simply press the Speaker key when placing or answering a call. The telephone line will activate automatically. The Speaker key will light up indicating that the speakerphone is in use. To hang up, press the Speaker key again.

Programming

PROGRAM SPEED DIALS USING SUBMERGED [STORE] AND [FLASH]

[Store] and [Flash] programming keys are located under the faceplate and overlay. Access them by lifting up the faceplate and overlay, using either a paperclip or sharp pointer.

STORING A NUMBER INTO MEMORY KEYS—[STORE]

Each speed-dial location can store up to 32 digits in tone mode.

Note: *Flash programmed into memory counts as one digit when storing a number.*

1. Lift the handset.
2. Press the STORE key.
3. Enter the number to be stored using the numeric dial pad.
4. Press the desired memory location where the number is to be stored.
5. If additional numbers are to be stored, repeat steps 3 through 5.
6. Hang up the handset.

PROGRAMMING FLASH TIMING

Flash timing options are 100 ms through 1000 ms, programmable in 100 ms increments. The default Flash timing is 600 ms.

1. Lift the handset.
2. Press the STORE Key once.
3. Program FLASH by pressing 1 for 100 ms, 2 for 200 ms, etc.
4. Press STORE.
5. Press FLASH.
6. Hang up phone to exit programming.

PROGRAMMING PAUSE TIMING

Pause timing options are 1 second through 5 seconds, programmable in 1 second increments. The default pause timing is 3.5 seconds.

1. Lift the handset.
2. Press the STORE Key once.
3. Program PAUSE by pressing 1 for 1 second, 2 for 2 seconds, etc.
4. Press STORE.
5. Press PAUSE/REDIAL.
6. Hang up phone to exit programming.

FLASH HOOK FUNCTION—[FLASH]

The Flash function is used to access PBX features or Telco line features such as Call Waiting. The Flash function is a 600 ms timed line break. If the Flash function will be used often, store the feature into memory located for easy access as follows:

1. Lift the handset then press the STORE Key.
2. Press the FLASH Key.
3. Press the memory location wherein the [Flash] is to be stored.
4. Hang up the handset.

MESSAGE

Pressing the touch bar automatically turns on the speakerphone and then dials into a user-programmed voice mail system to retrieve messages.

1. Lift the handset.
2. Press the STORE Key.
3. Enter the number to be stored using the numeric dial pad.
4. Press the red Message Waiting bar to store.
5. Hang up the handset.

Care and Maintenance

- **Keep the telephone dry.** If it gets wet, wipe it dry immediately. Liquids might contain minerals that can corrode the electronic circuits.
- **Use and store the telephone in a normal temperature environment.** Temperature extremes can shorten the life of electronic devices and distort or melt parts.
- **Keep the telephone away from excessive dust and dirt** which can cause premature wear of parts.
- **Wipe the telephone with a damp cloth** occasionally to keep it looking new. Do not use harsh chemicals, cleaning solvents, or strong detergents to clean the system.

Unpacking Your Telephone

This package should contain the following:

- Telephone base unit
- Mobile handset
- Paper faceplate
- Protective plastic overlay
- Power adaptor (direct connect -7.5 300mA)
- Handset battery
- Two rubber plugs for the handset cover
- Two screws to secure the top and bottom handset

Optional items to be ordered separately:

- Handset package: charging station, power adaptor, battery, handset, 2 rubber plugs, and 2 handset screws

Installation

CAUTION INFORMATION

- Never install telephone or network wiring during a lightning storm.
- Never install telephone or Ethernet jacks in wet locations unless the jack is specially designed for wet locations.
- Never touch uninstalled telephone wires or terminals unless the telephone line has been disconnected at the network interface.
- Use caution when installing or modifying telephone and network lines.
- Be sure your power adaptor meets your regions requirements prior to installation.

CONNECTING THE POWER LINE CORD

Two line cords are provided: 1-RJ45 and 1-RJ11.

To install, simply plug one end of the RJ45 cord into the modular jack at the top end of the base unit and the other end into the RJ45 phone jack on the power adaptor. Take the other RJ11 line cord and plug into the line jack on the power adaptor, then plug the other end into the wall. Finish by plugging the power adaptor into a normal wall outlet.

Be sure your power adaptor is specified for your region of the world prior to plugging it into the wall socket.

HANDSET BATTERY

Charging the Handset Battery (On Base and Charging Station):

The handset battery is a Ni-MH battery. This battery requires a full charge prior to use to ensure long life. To charge the battery, complete the installation procedure by plugging the power source into the wall outlet and the telephone base or charging station.

Install the battery per instructions, inserting battery plug into receptacle.

Place battery into opening in handset, press into place, then replace cover and place handset into base (face down) or charging station (face down).

BATTERY LIFE—WHEN COMPLETELY CHARGED

- **Talk time: 7.5 hours**
- **Standby (handset off-hook): 6 days**
- **Charge for 24 hours to ensure a fully-charged battery**

INSTALLING THE BATTERY INTO THE HANDSET

1. Hold the handset and gently push up the handset back shell.
2. Slide the back shell, exposing the battery compartment.
3. Install the battery plug into the receptacle, matching up slot and opening on the receptacle (do not force the battery).
4. Press battery into battery compartment
5. Slide the back shell of handset into slot, then press down and snap into place.
6. Insert screws and gently tighten.
7. Insert rubber screw cover plugs.

Features

- Phone circuit can directly drive hands-free
- Digital wireless/no interference technology
- 12 programmable speed-dial keys for storing up to 24 elements (digits and characters such as *, #, Flash, and Pause)
- Message Waiting Indicator and OneTouch message retrieval key integrated into design
- Handset auto-sync registration
- Each base unit can register up to 4 additional handsets
- Handset battery low-voltage warning
- Message high- and low-voltage detection
- Message for reverse polarity Line 1 or Line 2
- Extension detection function
- 6-ringer option (using the handset numeric keypad 1–6)

Operation

It's important to note that both the handset and the base need time to "boot up" when first powered up. The base station may require up to 1 full minute after applying AC power. For the handset it can also take up to 1 full minute after putting in the battery. In the case of a discharged battery the handset may need to charge for a minimum of 10 to 15 minutes before it will begin to operate properly.

VOLUME CONTROL

Ringer volume control: The ringer volume is controlled by the "Volume +/-" keys.

There are 5 steps to the volume levels. When you have reached the maximum or minimum sound level there will be a warning beep.

HANDSET VOLUME CONTROLS

The handset volume controls increase or decrease the volume of the handset.

When the handset is off-hook or the Speaker key engaged on speakerphones, press the volume control keys to increase or decrease the volume.

The handset volume control is a 5-step operation. All models are hearing aid compatible.

ON-HOOK AND OFF-HOOK/PICK-UP AND HANG-UP

Base unit: To get a dial tone with off-hook status, press line key to pick up with speaker. To go on-hook, press line key or speaker key to hang-up.

Handset: Press On/Off key in the handset faceplate to pick-up or hang-up.

HOLD

Base unit and handset: Controls the "local hold" function. Each press of the [Hold] key toggles local hold mode on or off. An LED indicator located above the [Hold] key displays the on-hold status.

MUTE

The Mute key toggles the microphone mute function on and off. The LED indicator above the [Mute] key displays the On/Off status of the mute function. When Mute is on, the handset and hands-free microphone audio are turned off. You will be able to hear the party at the other end of your call, but they will not be able to hear you.

REDIAL

Redials the last-dialed telephone number, up to 24 digits. After 30 minutes, the redial number will automatically be removed (for security and privacy).

MESSAGE

1. The hidden 3-position switch marked TYPE LR1 LR2 configures the message-waiting lamp.
2. For most applications the TYPE position will work. This is the factory default setting. Always try the TYPE position first: If the message lamp blinks when a message is in the mailbox, this confirms that TYPE is the correct setting.

3. For some PBX systems that provide reverse polarity message signaling, it may be necessary to move the switch to either LR1 or LR2. The correct position of the switch will cause the message lamp to be on continuously when a message is in the mailbox.

PAGE

CALL THE HANDSET

Press the base unit's Page key to call the handset, and the handset's message and On/Off indicator lights flash. Press the Page key again or any key in the handset or place the handset into the cradle to end the page.

REGISTERING A HANDSET

Auto-Sync Handset Registration

Pairing the handset to the base is an easy process that should need to be performed only once. After installing the battery, and securing the cover with the 2 screws provided, place the handset into the base unit cradle and make sure the charging leads make contact. The LED above Line 1 will light up and begin to blink rapidly, as the base and the handset enter Registration mode. The Registration process may take as long as 1 minute to complete, as the handset and base station exchange large amounts of encoded data. When the base and the handset have successfully paired, the phone will beep a Registration confirmation tone.

Each handset can sync with only ONE base station at a time. When a handset gets moved to a different base station, it will immediately sync with the new base station. After this the handset is no longer synced with its original base station, which means that if a cordless handset is accidentally moved into a different room, then the handset will wind up synced with the base station in the new room.

SWITCH BETWEEN BASE AND HANDSET

If the handset is registered with the base unit then the handset and base can switch the call freely. To switch from the handset to the base, press the Speaker key in the base unit and then press the On/Off key in the handset to switch from base to handset.

SWITCH BETWEEN HANDSETS

Every base unit can register up to 4 additional handsets. If one of the handsets is picking up a call, any one of the other handsets can pick up the call by pressing the On/Off key. The On/Off indicator of the other handsets will flash to display that the phone is in use.

SPEED DIALING FROM THE HANDSET

The handset can access 6 different speed-dial numbers programmed in the base.

Pressing down the **1** key for 3 seconds will call the number stored in **Message** on the base unit.

Press down the **2** key for 3 seconds to call the number stored in **M2** on the base unit.

Press down the **3** key for 3 seconds to call the number stored in **M3** on the base unit.

Press down the **4** key for 3 seconds to call the number stored in **M4** on the base unit.

Press down the **5** key for 3 seconds to call the number stored in **M5** on the base unit.

Press down the **6** key for 3 seconds to call the number stored in **M6** on the base unit.

Programming

PROGRAM SPEED-DIALS USING SUBMERGED [STORE] AND [FLASH]

[Store] and [Flash] programming keys are located under the faceplate and overlay. Begin by lifting up faceplate and overlay using either a paperclip or sharp pointer.

STORING A NUMBER INTO MEMORY KEYS—[STORE]

Each speed-dial location can store up to **24** digits in tone mode.

Note: *Flash programmed into memory counts as one digit when storing a number.*

1. Leave handset in cradle/on-hook.
2. Press the STORE key.
3. Enter the number to be stored using the numeric dial pad.
4. Press STORE key.
5. Press the desired memory location where the number is to be stored.
6. If additional numbers are to be stored, repeat steps 2 through 5.

PROGRAMMING FLASH TIMING

Flash timing options are 100 ms through 1000 ms, programmable in 100 ms increments. The default Flash timing is 600 ms.

1. Leave handset in cradle/on-hook.
2. Press the STORE key once.
3. Program Flash by pressing 1 for 100 ms, 2 for 200 ms, etc.
4. Press STORE key.
5. Press FLASH key.

PROGRAMMING PAUSE TIMING

Pause timing options are 1 second through 5 seconds, programmable in 1 second increments. The default pause timing is 3.5 seconds.

1. Leave handset in cradle/on-hook.
2. Press the STORE key once.
3. Program PAUSE by pressing 1 for 1 second, 2 for 2 seconds, etc.
4. Press STORE key.
5. Press PAUSE/REDIAL key.

FLASH HOOK FUNCTION—[FLASH]

The Flash function is used to access PBX features or Telco line features such as Call Waiting. The Flash function is a 600 ms timed line break. If the Flash function will be used often, store the feature into memory located for easy access as follows:

1. Leave handset in cradle/on-hook.
2. Press STORE key.
3. Press FLASH key.
4. Press STORE key.
5. Press the memory location where the FLASH is to be stored.

MESSAGE WAITING AND RETRIEVAL

Pressing the touch bar automatically turns on the speakerphone and then dials into a user-programmed voice mail system to retrieve messages.

1. Leave handset in cradle/on-hook.
2. Press STORE key.
3. Enter the number to be stored using the numeric dial pad.
4. Press STORE key.
5. Press the red Message Waiting bar to store.

In Case of Power Outage

The phone base will function without commercial power (but the handset will not operate).

Ringer: When receiving a new call, the phone base will ring, but not the handset.

Pick up: Press the line key to pick up/go off-hook.

Dial: Under off-hook status, the loudspeaker and microphone will receive sound, and calls can be placed using the dial pad.

Hang-up: After talking, press the speaker or line key to hang up.

Note: *Without commercial power, the base unit only supports dialing and calling; the indicator lights will fail to light; and the Redial, Hold, Flash, and handset will not operate.*

Care and Maintenance

- **Keep the telephone dry.** If it gets wet, wipe it dry immediately. Liquids might contain minerals that can corrode the electronic circuits.
- **Use and store the telephone in a normal temperature environment.** Temperature extremes can shorten the life of electronic devices and distort or melt parts.
- **Keep the telephone away from excessive dust and dirt** which can cause premature wear of parts.
- **Wipe the telephone with a damp cloth** occasionally to keep it looking new. Do not use harsh chemicals, cleaning solvents, or strong detergents to clean the system.

Unpacking Your Telephone

This package should contain the following:

- Telephone base unit
- Handset
- Coiled handset cord
- 1 straight line cord

Optional items to be ordered separately:

- Wall mount adaptor bracket
- Short line cord for wall mounting

Installation

CAUTION INFORMATION

- Never install telephone or network wiring during a lightning storm.
- Never install telephone or Ethernet jacks in wet locations unless the jack is specifically designed for wet locations.
- Never touch uninstalled telephone wires or terminals unless the telephone line has been disconnected at the network interface.
- Use caution when installing or modifying telephone and network lines.

CONNECTING THE HANDSET CORD

A 10 ft. modular handset coil cord is provided. To install, simply plug one end of the coil cord into the jack at the base of the handset, and the other end into the jack located on the end of the telephone base marked Handset.

CONNECTING THE LINE CORD

A 12 ft. modular line cord is provided. To install, simply plug one end of the cord into the modular jack at the top end of the base unit and the other end into the wall jack.

Features

1. **Speed-Dial Memory Keys:** 4, 8, 12, or 0 user-programmable speed-dial keys

with 32 digit capacity. [Flash] and [Pause] are storable. Speed-dial memory is non-volatile RAM, so programming is retained without the need for batteries or telephone line power.

2. **Line 1 Key:** Press Line 1 to place a call to a party on Line 1. Place the call on hold if you want to initiate a call on Line 2.
3. **Line 2 Key:** Press Line 2 to place a call to a party on Line 2. Place the call on hold if you want to initiate a call on Line 1.
4. **CONF (Conference) Key:** The Conf key allows three-way conversations. Depending on the situation, you may initiate a conference call using one of these methods:

CASE A—USER INITIATES TWO CALLS

1. Place your call to the first party, then put them on hold by pressing the **Hold** key.
2. Using the second line (Line 2), place your call to the second party, then place them on hold by pressing the **Hold** key.
3. Activate the conference by joining the calls together when you press the Conf key.

CASE B—USER RECEIVES A CALL AND PLACES A SECOND CALL

1. Receive a call from the first party then put them on hold by pressing the **Hold** key.
2. Using the second line (Line 2), place call to second party, then place them on hold by pressing the **Hold** key.
3. Activate the conference joining the calls together by pressing the Conf key.

CASE C—USER RECEIVES A CALL AND THEN RECEIVES A SECOND CALL

1. Receive the call from the first party and put them on hold by pressing the **Hold** key.
2. Using the second line (Line 2), place your call to the second party, then put them on hold by pressing the **Hold** key.

3. Activate the conference call by pressing the Conf key which will join the calls together.

TO TERMINATE A CONFERENCE CALL

Pressing a line key will maintain the connection with that line while dropping the other line. To terminate the call entirely, place the handset back in the cradle to go on-hook and disconnect both parties.

5. **FLASH Key:** Generates a 600 ms (0.6 seconds) hook switch “tap” signal. Utilized to access special features on PBX systems. The Flash function is programmable at 100 ms to 1000ms (default is 600 ms). This button is located underneath the faceplate.
6. **REDIAL Key:** Redials the last-dialed telephone number, up to 32 digits.
7. **MUTE Key:** Sets the microphone Mute function On and Off. The LED indicator above the [Mute] key displays the On/Off status of the Mute function. When Mute is On, the handset and hands-free microphone audio is turned off. You will be able to hear the party at the other end of your call, but they will not be able to hear you.
8. **HOLD Key:** Controls the “local hold” function. Each press of the [Hold] key toggles the local hold mode on or off. An LED indicator located above the [Hold] key displays the on-hold status
9. **SPEAKER Key:** Sets the hands-free speakerphone function On or Off. The LED indicator located above the [Speaker] key displays the On/Off status of the speakerphone.
10. **STORE Key:** Utilized to program the speed-dial memory keys and the voice mail retrieval touch bar. This button is located underneath the faceplate.

11. **Data Port:** Provides a convenient extension of the connected telephone line for connecting a device such as a modem, fax, or answering machine.

Operation

VOLUME

HANDSET AND SPEAKER VOLUME CONTROL

The handset volume control increases the volume of the handset.

When the handset is off-hook or the Speaker key is engaged on the speakerphones, press the volume control keys to increase or decrease the volume. The handset volume control is an 8-step operation. All models are hearing aid compatible.

RINGER VOLUME CONTROL

The ringer volume control switch is on the bottom side of the phone.

The setting is either Low or HI (High).

INDICATORS

SPEAKER AND MUTE KEY CONNECTING AND STATUS INDICATORS

Speakerphones are equipped with LED indicators to show the current feature key status.

- Press Speaker or Mute feature key to use that service—the LED will light red when that key is IN USE.

CALLING

PLACING A CALL USING THE HANDSET

- Lift the handset.
- Dial out by using the numeric dial pad or by pressing a speed dial location.

RECEIVING A CALL USING THE HANDSET OR SPEAKER

On a two-line telephone, when the phone rings select the ringing line (which will engage the Speaker) or lift the handset to begin the conversation.

PLACING A CALL USING THE SPEAKERPHONE

The E Series speakerphones are equipped with a high-quality speakerphone feature to allow hands-free operation. To use, simply press the Speaker key when placing or answering a call. The telephone line will activate automatically. The Speaker key will light up indicating that the speakerphone is in use. To hang up, press the Speaker key again.

Programming

PROGRAM SPEED DIALS USING SUBMERGED [STORE] AND [FLASH]

Store and Flash programming keys are located under the faceplate and overlay. Lift up faceplate and overlay by using either a paperclip or sharp pointer.

STORING A NUMBER INTO MEMORY KEYS—[STORE]

Each speed-dial location can store up to 32 digits in tone mode.

Note: *Flash programmed into memory counts as one digit when storing a number.*

1. Lift the handset.
2. Press the STORE key.
3. Enter the number to be stored using the numeric dial pad.
4. Press the desired memory location wherein the number is to be stored.
5. If additional numbers are to be stored, repeat steps 3 through 5.
6. Hang up the handset.

PROGRAMMING FLASH TIMING

Flash timing options are 100 ms through 1000 ms, programmable in 100 ms increments. The default Flash timing is 600 ms.

1. Lift the handset (off-hook position).
2. Press the STORE key once.
3. Program FLASH by pressing 1 for 100 ms, 2 for 200 ms, etc.
4. Press STORE.
5. Press FLASH.
6. Exit programming by hanging up the handset.

PROGRAMMING PAUSE TIMING

Pause timing options are 1 second through 5 seconds, programmable in 1 second increments. The default pause timing is 3.5 seconds.

1. Lift the handset (off-hook position).
2. Press the STORE key once.
3. Program PAUSE by pressing 1 for 1 second, 2 for 2 seconds, etc.
4. Press STORE.
5. Press PAUSE/REDIAL.
6. Exit programming by hanging up the handset.

FLASH HOOK FUNCTION—[FLASH]

The Flash function is used to access PBX features or Telco line features such as Call Waiting. The Flash function is a 600 ms timed line break. If the Flash function will be used often, store the feature into memory located for easy access as follows:

1. Lift the handset then press the STORE key.
2. Press the FLASH key.
3. Press the memory location where the FLASH is to be stored.
4. Hang up the handset.

MESSAGE

Pressing the touch bar automatically turns on the speakerphone, and then dials into a user-programmed voicemail system to retrieve messages.

1. Lift the handset.
2. Press the STORE key.
3. Enter the number to be stored using the numeric dial pad.
4. Press the red Message Waiting bar to store.
5. Hang up the handset.

Care and Maintenance

- **Keep the telephone dry.** If it gets wet, wipe it dry immediately. Liquids might contain minerals that can corrode the electronic circuits.
- **Use and store the telephone in a normal temperature environment.** Temperature extremes can shorten the life of electronic devices and distort or melt parts.
- **Keep the telephone away from excessive dust and dirt** which can cause premature wear of parts.
- **Wipe the telephone with a damp cloth** occasionally to keep it looking new. Do not use harsh chemicals, cleaning solvents, or strong detergents to clean the system.

Unpacking Your Telephone

This package should contain the following:

- Telephone base unit
- Mobile handset
- Paper faceplate
- Protective plastic overlay
- Power adaptor (direct connect -7.5 300mA)
- Handset battery
- Two rubber plugs for the handset cover
- Two screws to secure the top and bottom handset

Optional items to be ordered separately:

- Handset package: charging station, power adaptor, battery, handset, 2 rubber plugs, and 2 handset screws

Installing the Phone

CAUTION INFORMATION

- Never install telephone or network wiring during a lightning storm.
- Never install telephone or Ethernet jacks in wet locations unless the jack is specially designed for wet locations.
- Never touch uninstalled telephone wires or terminals unless the telephone line has been disconnected at the network interface.
- Use caution when installing or modifying telephone and network lines.
- Be sure your power adaptor meets your regions requirements prior to installation.

CONNECTING THE POWER LINE CORD

Two line cords are provided: one RJ45 and one RJ11.

To install, simply plug one end of the RJ45 cord into the modular jack at the top end of the base unit and the other end into the RJ45 phone jack on the power adaptor. Take the other RJ11 line cord and

plug into the line jack on the power adaptor, then plug the other end into the wall. Finish by plugging the power adaptor into normal wall outlet.

Be sure your power adaptor is specified for your region of the world prior to plugging into the wall socket.

HANDSET BATTERY

CHARGING THE HANDSET BATTERY (ON BASE AND CHARGING STATION)

The handset battery is a Ni-MH battery. This battery requires a full charge prior to use to ensure long life. To charge the battery, complete the installation procedure by plugging the power source into the wall outlet and the telephone base or charging station.

Install the battery per instructions, inserting battery plug into receptacle.

Place the battery in the opening in the handset, press into place, then replace cover, and place handset into base (face down) or charging station (face down).

BATTERY LIFE—WHEN COMPLETELY CHARGED

- **Talk time: 7.5 hours**
- **Standby (handset off hook): 6 days**
- **Charge for 24 hours to ensure a fully charged battery**

INSTALLING THE BATTERY INTO THE HANDSET

1. Hold the handset and gently push up the handset back shell.
2. Remove the back, exposing the battery compartment.
3. Slide the battery plug into its receptacle, matching up slot and opening on receptacle.
4. Do not force the battery.

5. Press on back end of battery to snap into place.
6. Put the back shell of handset into slot, then press down and snap into place.

Features

- Phone circuit can directly drive hands-free
- Digital wireless/no interference technology
- 12 programmable speed dial keys for storing up to 24 elements (digits and characters such as *, #, Flash, and Pause)
- Message Waiting Indicator and OneTouch message retrieval key integrated into design
- Handset auto-sync registration
- Each base unit can register up to 4 additional handsets
- Handset battery low-voltage warning
- Message high- and low-voltage detection
- Message for reverse polarity Line 1 or Line 2
- Extension detection function
- 6-ringer option (using the handset numeric keypad 1-6)

Operation

VOLUME CONTROL

Ringer volume control: The ringer volume is controlled via the “ Volume +/- ” key.

There are five volume levels. When you have reached the maximum or minimum sound level there will be a warning beep.

HANDSET VOLUME CONTROLS

The handset volume control increases the volume of the handset.

When the handset is off-hook or the Speaker key engaged on speakerphones, press the Volume Control keys to increase or decrease the volume. The handset volume control is a 5-step operation. All models are hearing aid compatible.

ON-HOOK AND OFF-HOOK/PICK-UP AND HANG-UP

Base unit: To get a dial tone with off-hook status, press a line key or the Speaker key to pick up with speaker. To hang up or go on-hook, press a line or the Speaker key again to hang-up.

Handset: Press ON/OFF key in the handset faceplate to pickup or hang-up.

HOLD

Base unit and handset: Controls the “local hold” function. Each press of the [Hold] key toggles the local hold mode On or Off. An LED indicator located above the [Hold] key displays the on-hold status.

MUTE

The Mute key toggles the microphone Mute function On and Off. The LED indicator above the [Mute] key displays the On/Off status of the Mute function. When Mute is on, the handset and hands-free microphone audio are turned off. You will be able to hear the party at the other end of your call, but they will not be able to hear you.

REDIAL

Redials the last-dialed telephone number, up to 24 digits. After 30 minutes, the redialed number will automatically be removed (for security and privacy).

MESSAGE

1. The hidden 3-position switch marked TYPE LR1 LR2 configures the message-waiting lamp.
2. For most applications the TYPE position will work. This is the factory default setting. Always try the TYPE position first: If the message lamp blinks when a message is in the mailbox, this confirms that TYPE is the correct setting.
3. For some PBX systems that provide reverse polarity message signaling, it may

be necessary to move the switch to either LR1 or LR2. The correct position of the switch will cause the message lamp to be on continuously when a message is in the mailbox.

PAGE

CALL THE HANDSET

Press the base unit's Page key to call the handset and the handset's Message and On/Off indicator lights flash. Press the Page key again (or any key in the handset or place the handset into the cradle) to end the page.

CONFERENCE

The CONF key allows for three-way conversations. Depending on the situation, you may initiate a conference call using one of these methods:

CASE A—USER INITIATES 2 CALLS

1. Place your call to the first party, then put them on hold by pressing the HOLD key.
2. Using the second line (Line 2), place your call to the second party, then put them on hold by pressing the HOLD key.
3. Activate Conference by pressing the CONF key to join the calls together.

CASE B—USER RECEIVES A CALL AND PLACES A SECOND CALL

1. Receive a call from the first party, then put them on hold by pressing the HOLD key.
2. Using the second line (Line 2), place a call to the second party, then put them on hold by pressing the HOLD key.
3. Activate Conference by pressing the CONF key to join the calls together.

CASE C—USER RECEIVES A CALL AND THEN RECEIVES A SECOND CALL

1. Receive a call from the first party, then put them on hold by pressing the HOLD key.
2. Using the second line (Line 2), place a call to the second party, then put them on hold by pressing the HOLD key.
3. Activate Conference by pressing the CONF key to join the calls together.

TO TERMINATE A CONFERENCE CALL

Pressing a Line key will maintain the connection with that line while dropping the other line. To terminate the call entirely, place the handset back in the cradle to go on-hook and disconnect both parties.

REGISTERING A HANDSET

AUTO-SYNC REGISTRATION

Place the handset into the base unit cradle and make sure the charging leads make contact. The Line will light up, and the base and the handset will enter Registration mode. When the base and the handset have successfully paired, the phone will beep a Registration confirmation tone.

SWITCH BETWEEN BASE AND HANDSET

If the handset is registered with the base unit, then the handset and base can switch the call freely. To switch from the handset to the base, press the Speaker key in the base unit. Press the ON/OFF key in the handset to switch from base to handset.

SWITCH BETWEEN HANDSETS

Every base unit can register up to 4 additional handsets. If one of the handsets is picking up, any one of the other handsets can pick up the call by

pressing the ON/OFF key. The ON/OFF indicator of the other handsets will flash to display the phone is in use.

SPEED DIALING FROM THE HANDSET

The handset can access 6 different speed dial numbers programmed in the base.

Pressing down the **1** key for 3 seconds will call the number stored in **Message** on the base unit.

Press down the **2** key for 3 seconds to call the number stored in **M2** on the base unit.

Press down the **3** key for 3 seconds to call the number stored in **M3** on the base unit.

Press down the **4** key for 3 seconds to call the number stored in **M4** on the base unit.

Press down the **5** key for 3 seconds to call the number stored in **M5** on the base unit.

Press down the **6** key for 3 seconds to call the number stored in **M6** on the base unit.

If the base unit cannot store any number, these operations can only pick up with the handset.

Programming

PROGRAM SPEED DIALS USING SUBMERGED [STORE] AND [FLASH]

[Store] and [Flash] programming keys are located under the faceplate and overlay; begin by lifting up faceplate and overlay, by either a paperclip or sharp pointer.

STORING A NUMBER INTO MEMORY KEYS—[STORE]

Each speed-dial location can store up to **24** digits in tone mode.

Note: *Flash programmed into memory counts as one digit when storing a number.*

1. Remove Faceplate.
2. Press STORE button (revealed by removing faceplate).

3. Dial the number you want to store.
4. Press STORE button (revealed by removing faceplate).
5. Press the memory button.

PROGRAMMING FLASH TIMING

Flash timing options are 100 ms through 1000 ms, programmable in 100 ms increments. The default Flash timing is 600 ms.

1. Lift the handset (off-hook position).
2. Press the STORE key once.
3. Program FLASH by pressing 1 for 100 ms, 2 for 200 ms, etc.
4. Press STORE.
5. Press FLASH.
6. Hang up the handset to exit programming.

PROGRAMMING PAUSE TIMING

Pause timing options are 1 second through 5 seconds, programmable in 1 second increments. The default pause timing is 3.5 seconds.

1. Lift the handset (off-hook position).
2. Press the STORE key once.
3. Program Pause by pressing 1 for 1 second, 2 for 2 seconds, etc.
4. Press STORE.
5. Press PAUSE/REDIAL.
6. Hang up the handset to exit programming.

FLASH HOOK FUNCTION—[FLASH]

The Flash function is used to access PBX features or Telco line features such as Call Waiting. The Flash function is a 600 ms timed line break. If the Flash function will be used often, store the feature into memory located for easy access as follows:

1. Lift the handset then press the STORE key.
2. Press the FLASH key.
3. Press the memory location wherein the FLASH is to be stored.
4. Hang up the handset.

MESSAGE WAITING AND RETRIEVAL

Pressing the touch bar automatically turns on the speakerphone, and then dials into a user-programmed voicemail system to retrieve messages.

1. Remove Faceplate.
2. Press STORE button (revealed by removing faceplate).
3. Dial the number you want to store.
4. Press STORE button (revealed by removing faceplate).
5. Press the Message Waiting button button.

In Case of Power Outage

The phone base will function without commercial power (but the handset will not operate).

Ringer: When receiving a new call, the phone base will ring, but not the handset.

Pick up: Press the Line or Speaker key to pick up.

Dial: Under off-hook status the loudspeaker and microphone will receive sound and calls can be placed using the dial pad.

Hang-up: After talking, press the Speaker or Line key to hang up.

Note: *Without commercial power, the base unit only supports dialing and calling; the indicator lights will*

fail to light; and Redial, Hold, Flash, and the handset will not operate.

Care and Maintenance

- **Keep the telephone dry.** If it gets wet, wipe it dry immediately. Liquids might contain minerals that can corrode the electronic circuits.
- **Use and store the telephone in a normal temperature environment.** Temperature extremes can shorten the life of electronic devices and distort or melt parts.
- **Keep the telephone away from excessive dust and dirt** that can cause premature wear of parts.
- **Wipe the telephone with a damp cloth** occasionally to keep it looking new. Do not use harsh chemicals, cleaning solvents, or strong detergents to clean the system.

Important Safety Instructions

When using your telephone equipment, basic safety precautions should always be followed to reduce the risk of fire, electric shock, and injury to persons, including the following:

1. Read and understand all instructions.
2. Follow all warnings and instructions marked on the product.
3. Unplug the product from the wall outlet before cleaning. Do not use liquid cleaner or aerosol cleaners. Use a damp cloth for cleaning.
4. Do not use this product near water—for example, near a bathtub, wash bowl, kitchen sink or laundry tub, in a wet basement, or near a swimming pool.
5. Do not place this product on an unstable cart, stand, or table. The product may fall, causing serious damage to the product.
6. Slots and openings in the cabinet and the back or bottom are provided for ventilation, to protect it from overheating. These openings must not be blocked or covered. The openings should never be blocked by placing the product on the bed, sofa, rug, or any other similar surface. This product should never be placed near or over a radiator or heat register. This product should not be placed in a built-in installation unless proper ventilation is provided.
7. Never push objects of any kind into this product through cabinet slots as they may touch dangerous voltage points or short out parts that could result in a risk of fire or electric shock. Never spill liquid of any kind on the product.
8. To reduce the risk of electric shock do not disassemble this product. Take it to a qualified service facility if service or repair work is required. Opening or removing covers may expose you to dangerous voltages or other risks. Incorrect reassembly can cause electric shock when the appliance is subsequently used.
9. Unplug this product from the wall outlet and refer servicing to qualified service personnel under the following conditions:
 - When the power supply cord or plug is damaged or frayed.
 - If liquid has been spilled into the product.
 - If the product has been exposed to rain or water.
 - If the product does not operate normally by following the operating instructions. Adjust only those controls that are covered by the operating instructions, as improper adjustment of other controls may result in damage and may require extensive work by a qualified technician to restore the product to normal operation.
 - If the product has been dropped or the cabinet has been damaged.
 - If the product exhibits a distinct change in performance.
10. Avoid using a telephone (other than a cordless type) during an electrical storm. There may be a remote risk of electric shock from lightning.
11. Do not use the telephone to report a gas leak in the vicinity of the leak.

PLEASE SAVE THESE INSTRUCTIONS.

FCC Interference Information

This device complies with Part 15 of the FCC Rules. Operation is subject to the following two conditions:

1. This device may not cause harmful interference.
2. This device must accept any interference received, including interference that may cause undesired operation.

This equipment has been tested and found to comply with the limits for a Class B digital device, pursuant to Part 15 of the FCC Rules. These limits are designed to provide reasonable protection against harmful interference in a residential installation. This equipment generates, uses, and can radiate radio frequency energy and, if not installed and used in accordance with the instructions, may cause harmful interference to radio communications. However, there is no guarantee that interference will not occur in a particular installation.

If this equipment does cause harmful interference to radio or television reception, which can be determined by turning the equipment off and on, the user is encouraged to try to correct the interference by one or more of the following measures:

- Reorient or relocate the receiving antenna for the radio or television that is receiving the interference).
- Reorient or relocate and increase the separation between the telecommunications equipment and receiving antenna.
- Connect the telecommunications equipment into an outlet on a circuit different from that to which the receiving antenna is connected.

FCC RF Radiation Exposure Statement

The installation of the base unit should allow at least 20 centimeters between the base and persons to be in compliance with FCC RF exposure guidelines. For body-worn operation, the portable part (handset) has been tested and meets FCC RF exposure guidelines.

This device must not be co-located or operating in conjunction with any other antenna or transmitter. The changes or modifications not expressly approved by the party responsible for compliance could void the user's authority to operate the equipment.

Industry of Canada Requirements

Note: This equipment meets the applicable Industry Canada Terminal Equipment Technical Specifications. This is confirmed by the registration number. The abbreviation, IC, before the registration number signifies that registration was performed based on a Declaration of Conformity indicating that Industry Canada technical specifications were met. It does not imply that Industry Canada approved the equipment.

Before installing this equipment, users should ensure that it is permissible to be connected to the facilities of the local telecommunications company. The equipment must also be installed using an acceptable method of connection. The customer should be aware that compliance with the above conditions may not prevent degradation of service in some situations.

Repairs to certified equipment should be coordinated by a representative designated by the supplier. Any repairs or alterations made by a user to this equipment, or equipment malfunctions, may give the telephone communications company cause to request the user to disconnect the equipment.

Users should ensure for their own protection, that the electrical ground connections of the power utility, telephone lines, and internal metallic water pipe system, if present, are connected together. This precaution may be particularly important in rural areas.

Caution: Users should not attempt to make such connections themselves, but should contact the appropriate electric inspection authority, or electrician, as appropriate.

Notice: The Ringer Equivalence Number (REN) assigned to each terminal device provides an indication of the maximum number of terminals allowed to be connected to a telephone interface. The termination on an interface may consist

of any combination of devices subject only to the requirement that the sum of the Ringer Equivalence Numbers of all the devices does not exceed 5.

REN: Z

For warranty and service in Canada, please contact:

Williams Telecommunications
5610 Kennedy Road
Mississauga, Ontario, L4Z2A9
Canada
Phone: 905-712-4242
Fax: 905-712-1754

Requirements of Part 15— FCC Rules

Note: This equipment has been tested and found to comply with the limits for a Class B digital device, pursuant to Part 15 of the FCC Rules. These limits are designed to provide reasonable protection against harmful interference in a residential installation. This equipment generates, uses, and can radiate radio frequency energy and, if not installed and used in accordance with the instructions, may cause harmful interference to radio communications. However, there is no guarantee that interference will not occur in a particular installation. If this equipment does cause harmful interference to radio or television reception, which can be determined by turning the equipment off and on, the user is encouraged to try to correct the interference by one or more of the following measures:

1. Move the telephone away from the receiver.
2. Consult the dealer or an experienced radio/TV technician for help.

Any changes made by the user not approved by the manufacturer can void the user's authority to operate the telephone.

Requirements of Part 68— FCC Rules

This equipment complies with Part 68 of the FCC Rules and the requirements adopted by ACTA. On the bottom of this telephone is a label that contains, among other information, a product identifier in the format US:AAAEQ##TXXXX. If requested, this number must be provided to the telephone company. The USOC Jack for this equipment is RJ11C.

A plug and jack used to connect this equipment to the premises wiring and telephone network must comply with the applicable FCC Part 68 rules and requirements adopted by ACTA. A compliant telephone cord and modular plug are provided with this telephone. It is designed to be connected to a compatible modular jack that is also compliant. See installation instructions for details.

The Ringer Equivalence Number (REN) is used to determine the number of devices that may be connected to a telephone line. Excessive RENs on a telephone line may result in the devices not ringing in response to an incoming call. In most but not all areas, the sum of RENs should not exceed five (5.0). To be certain of the number of devices that may be connected to a line, as determined by the total RENs, contact the local telephone company. For products approved after July 23, 2001, the REN for this product is a part of the product identifier that has the format US:AAAEQ##TXXXX. The digits represented by ## are the REN without a decimal point (e.g., 03 is a REN of 0.3). For earlier products, the REN is separately shown on the label.

If this telephone causes harm to the telephone network, the telephone company will notify you in advance that temporary discontinuance of service may be required. But if advance notice is not practical, the telephone company will notify

the customer as soon as possible. Also, you will be advised of your right to file a complaint with the FCC if you believe it is necessary.

The telephone company may make changes in its facilities, equipment, operations, or procedures that could affect the operation of the equipment. If this happens, the telephone company will provide advance notice in order for you to make the necessary modifications to maintain uninterrupted service.

If trouble is experienced with this equipment, for repair or warranty information, please contact Teledex at (800) 462-9446. If the equipment is causing harm to the telephone network, the telephone company may request that you disconnect the equipment until the problem is resolved.

There are no user-serviceable parts contained in this equipment.

Connection to party line service is subject to state tariffs. Contact the state public utility commission, public service commission, or corporation commission for information.

If your home has specially wired alarm equipment connected to the telephone line, ensure the installation of this product does not disable your alarm equipment. If you have questions about what will disable alarm equipment, consult your telephone company or a qualified installer.

This telephone is hearing aid compatible.

These telephone devices are intended for commercial use only, primarily in hotel guestrooms. They must be used with a PBX (private branch

exchange), and are not intended to be connected directly to a PSTN line (public switched telephone network). There are no user-serviceable parts inside the equipment.

Technical Specifications

DIMENSIONS

4.5" (w) x 8" (l) x 3.63" (h)

WEIGHT

With handset: 1.4 lbs.

POWER ADAPTER

7.5VDC 300mA Adapter (for cordless HDKIT)

9 VDC 300mA (Pass through adapter for cordless telephone)

User Guides

If additional User Guides are needed, please go to www.teledex.com to download the PDF.

Service

When problems arise that cannot be resolved using this or related documents, please go to www.teledex.com/support for information about customer support, technical support, warranty, and product returns.

Statement of Limited Warranty

Teledex product warranty information is available at www.teledex.com.



Toll Free: +1.800.462.9446

Tel: +1.719.638.8821

Email: info@teledex.com

www.teledex.com